

MECHANIZED SEMANTICS AND VERIFIED COMPILATION FOR A DATAFLOW SYNCHRONOUS LANGUAGE WITH RESET

Timothy Bourke^{1,2} Lélío Brun^{1,2} Marc Pouzet^{3,2,1}

POPL'20 — January 24, 2020

¹Inria Paris

²École normale supérieure – PSL University

³Sorbonne University

`velus.inria.fr`
`github.com/INRIA/velus`

MOTIVATION: MODEL BASED DESIGN IN SCADE SUITE

www.ansys.com/products/embedded-software/ansys-scade-suite

The screenshot displays the SCADE Suite software interface with three main windows showing block diagrams:

- euler_1:** A block diagram with inputs u and x_0 . It contains a multiplier block (\times), an adder block ($+$), and a feedback block (FBY). The output is x .
- ins_1:** A block diagram with inputs gps and xv . It includes an "alarm WHEN" block, an "euler" block, and another "alarm" block. The output is x .
- nav_1:** A block diagram showing a state transition between two states: "GPS" and "INS". The "GPS" state has inputs gps and $false$ leading to outputs x and $alarm$. The "INS" state has inputs gps and xv leading to outputs x and $alarm$. Transitions between states are labeled with s and 1 .

The interface includes a menu bar (File, Edit, View, Operator, Insert, Layout, Project, Tools, Navigate, Window, Help), a toolbar, and a left-hand pane showing a project tree for "test.etp" with subfolders like "Operators", "libdigital", "liblinear", "libmath", "libmathext", "libpwnlinear", and "libverif".

MOTIVATION: MODEL BASED DESIGN IN SCADE SUITE

www.ansys.com/products/embedded-software/ansys-scade-suite

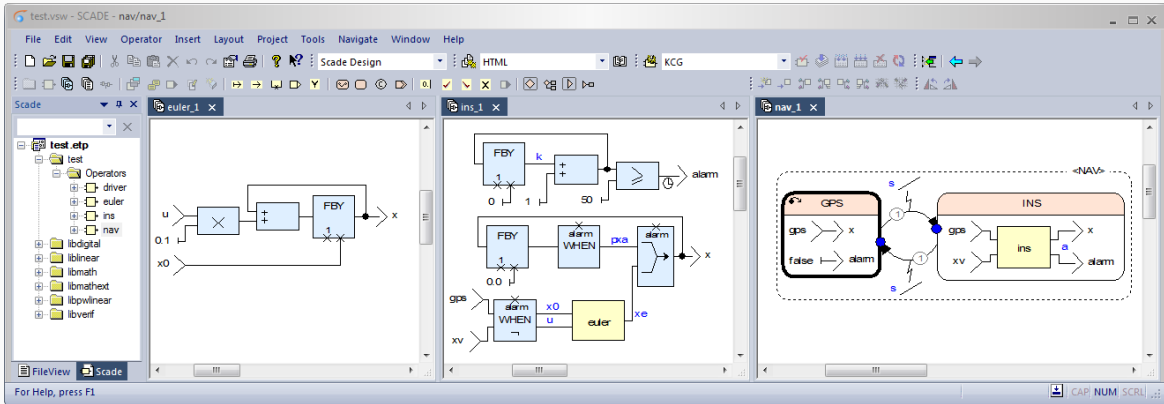

block / node = system

line = signal

MOTIVATION: MODEL BASED DESIGN IN SCADE SUITE

www.ansys.com/products/embedded-software/ansys-scade-suite

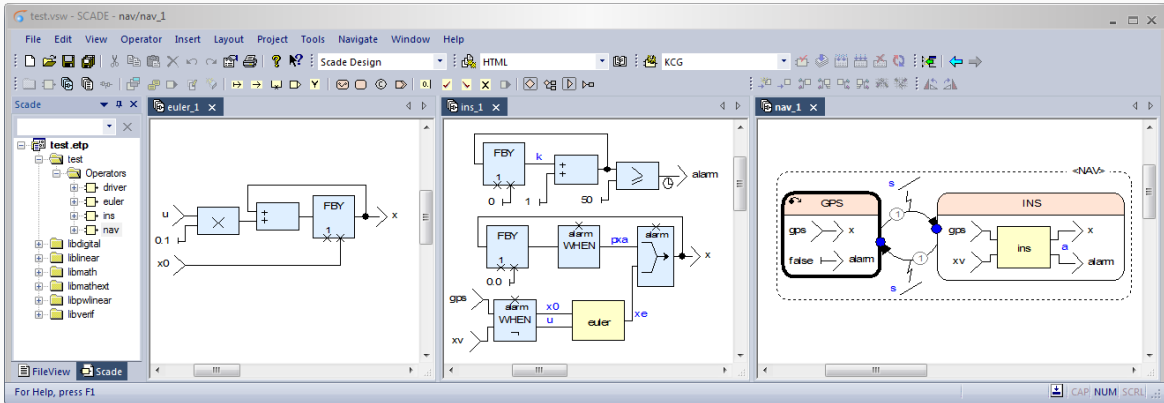

block / node = system = stream function
line = signal = stream of values

MOTIVATION: MODEL BASED DESIGN IN SCADE SUITE

www.ansys.com/products/embedded-software/ansys-scade-suite

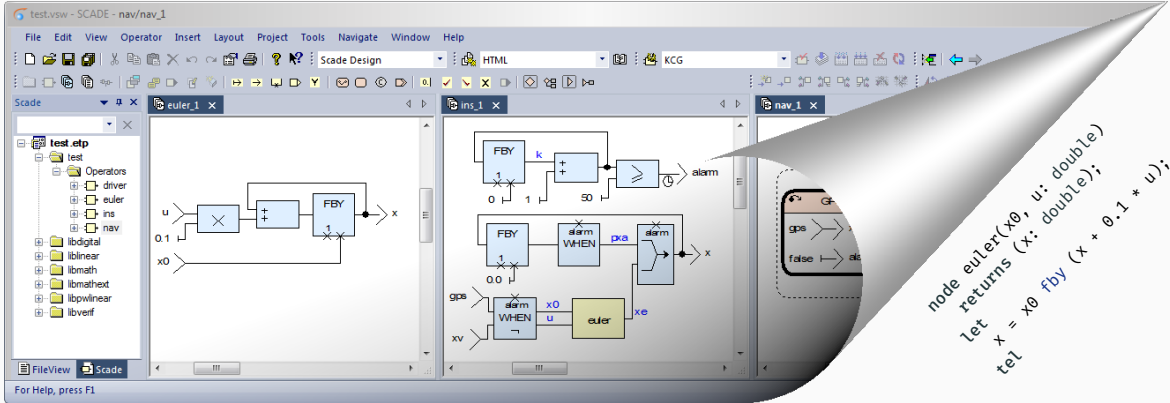

block / node = system = stream function
line = signal = stream of values

MOTIVATION: MODEL BASED DESIGN IN SCADE SUITE

www.ansys.com/products/embedded-software/ansys-scade-suite

The screenshot shows the SCADE Suite software interface. The main window displays a block diagram with several components: a multiplier block, an adder block, and a feedback block labeled 'FBY'. The diagram is connected to a navigation pane on the left showing a project structure with folders like 'test', 'Operators', 'driver', 'euler', 'ins', and 'nav'. A callout bubble on the right side of the interface contains the following code:

```
node euler(x0, u: double)  
returns (x: double);  
let  
  x = x0 fby (x + 0.1 * u);
```

An arrow points from the callout to a specific block in the diagram, illustrating the mapping between the graphical representation and the underlying code.

block / node = system = stream function
line = signal = stream of values

sequential program
(C, Ada, assembly)

Model-Based Design Languages

SCADE, Lustre, Simulink



Interactive Theorem Provers

Coq

Challenges

1. Mechanize the semantics
2. Prove the compilation algorithms correct

Model-Based Design Languages

SCADE, Lustre, Simulink



Interactive Theorem Provers

Coq

Challenges

1. Mechanize the semantics
2. Prove the compilation algorithms correct

Focus: modular reset

EXAMPLE

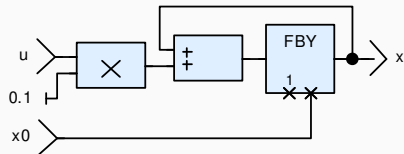

```

node euler(x0, u: double)
  returns (x: double);
let
  x = x0 fby (x + 0.1 * u);
tel

```

x_0	0.00	1.55	3.62	5.46	...
u	15.00	20.00	17.00	12.00	...
$x + 0.1 \times u$	1.50	3.50	5.20	6.70	...
x	0.00	1.50	3.50	5.20	...

EXAMPLE

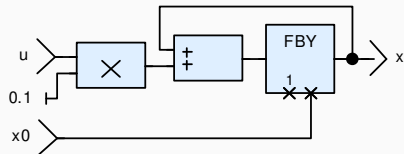

```
node euler(x0, u: double)
  returns (x: double);
let
  x = x0 fby (x + 0.1 * u);
tel
```

x_0	0.00	1.55	3.62	5.46	...
u	15.00	20.00	17.00	12.00	...
$x + 0.1 \times u$	1.50	3.50	5.20	6.70	...
x	0.00	1.50	3.50	5.20	...

EXAMPLE

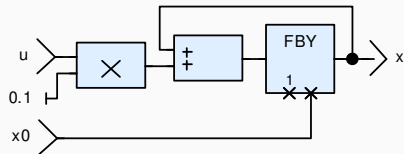

```
node euler(x0, u: double)
  returns (x: double);
let
  x = x0 fby (x + 0.1 * u);
tel
```

x_0	0.00	1.55	3.62	5.46	...
u	15.00	20.00	17.00	12.00	...
$x + 0.1 \times u$	1.50	3.50	5.20	6.70	...
x	0.00	1.50	3.50	5.20	...

EXAMPLE

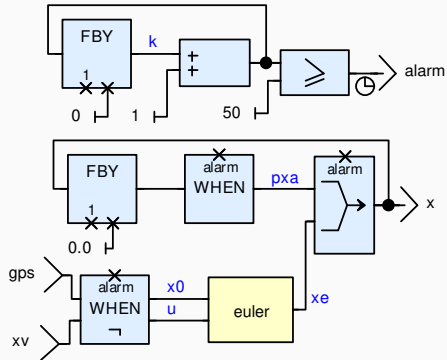

```

node ins(gps, xv: double)
  returns (x: double, alarm: bool)
  var pxa, xe: double; k: int;
  let
    k = 0 fby (k + 1);
    alarm = (k ≥ 50);
    xe = euler((gps, xv) when not alarm);
    pxa = (0. fby x) when alarm;
    x = merge alarm pxa xe;
  tel

```

<i>gps</i>	0.00	1.55	3.62	5.46	...	86.52	88.40	90.91	...
<i>xv</i>	15.00	20.00	17.00	12.00	...	18.00	23.00	20.00	...
<i>k</i>	0	1	2	3	...	49	50	51	...
<i>alarm</i>	F	F	F	F	...	F	T	T	...
<i>xe</i>	0.00	1.50	3.50	5.20	...	77.35			...
<i>pxa</i>					...		77.35	77.35	...
<i>x</i>	0.00	1.50	3.50	5.20	...	77.35	77.35	77.35	...

EXAMPLE

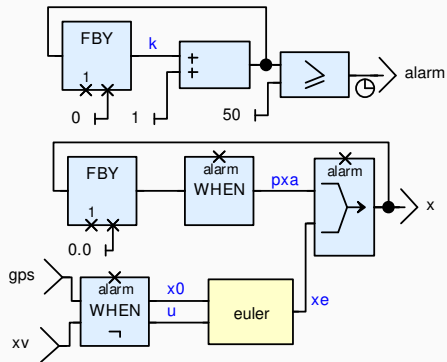

```

node ins(gps, xv: double)
  returns (x: double, alarm: bool)
  var pxa, xe: double; k: int;
  let
    k = 0 fby (k + 1);
    alarm = (k ≥ 50);
    xe = euler((gps, xv) when not alarm);
    pxa = (0. fby x) when alarm;
    x = merge alarm pxa xe;
  tel

```

<i>gps</i>	0.00	1.55	3.62	5.46	...	86.52	88.40	90.91	...
<i>xv</i>	15.00	20.00	17.00	12.00	...	18.00	23.00	20.00	...
<i>k</i>	0	1	2	3	...	49	50	51	...
<i>alarm</i>	F	F	F	F	...	F	T	T	...
<i>xe</i>	0.00	1.50	3.50	5.20	...	77.35			...
<i>pxa</i>					...		77.35	77.35	...
<i>x</i>	0.00	1.50	3.50	5.20	...	77.35	77.35	77.35	...

EXAMPLE

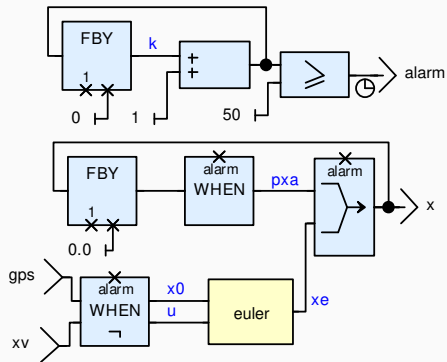

```

node ins(gps, xv: double)
  returns (x: double, alarm: bool)
  var pxa, xe: double; k: int;
  let
    k = 0 fby (k + 1);
    alarm = (k ≥ 50);
    xe = euler((gps, xv) when not alarm);
    pxa = (0. fby x) when alarm;
    x = merge alarm pxa xe;
  tel

```

gps	0.00	1.55	3.62	5.46	...	86.52	88.40	90.91	...
xv	15.00	20.00	17.00	12.00	...	18.00	23.00	20.00	...
<hr/>									
k	0	1	2	3	...	49	50	51	...
alarm	F	F	F	F	...	F	T	T	...
xe	0.00	1.50	3.50	5.20	...	77.35			...
pxa					...		77.35	77.35	...
x	0.00	1.50	3.50	5.20	...	77.35	77.35	77.35	...

EXAMPLE

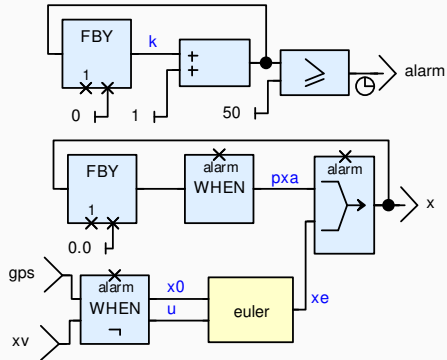

```

node ins(gps, xv: double)
  returns (x: double, alarm: bool)
  var pxa, xe: double; k: int;
  let
    k = 0 fby (k + 1);
    alarm = (k ≥ 50);
    xe = euler((gps, xv) when not alarm);
    pxa = (0. fby x) when alarm;
    x = merge alarm pxa xe;
  tel

```

<i>gps</i>	0.00	1.55	3.62	5.46	...	86.52	88.40	90.91	...
<i>xv</i>	15.00	20.00	17.00	12.00	...	18.00	23.00	20.00	...
<i>k</i>	0	1	2	3	...	49	50	51	...
<i>alarm</i>	F	F	F	F	...	F	T	T	...
<i>xe</i>	0.00	1.50	3.50	5.20	...	77.35			...
<i>pxa</i>					...		77.35	77.35	...
<i>x</i>	0.00	1.50	3.50	5.20	...	77.35	77.35	77.35	...

EXAMPLE

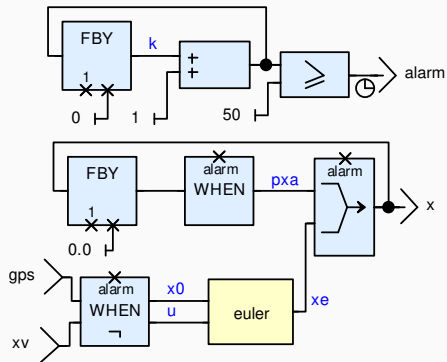

```

node ins(gps, xv: double)
  returns (x: double, alarm: bool)
  var pxa, xe: double; k: int;
  let
    x = merge alarm pxa xe;
    k = 0 fby (k + 1);
    pxa = (0. fby x) when alarm;
    xe = euler((gps, xv) when not alarm);
    alarm = (k ≥ 50);
  tel

```

<i>gps</i>	0.00	1.55	3.62	5.46	...	86.52	88.40	90.91	...
<i>xv</i>	15.00	20.00	17.00	12.00	...	18.00	23.00	20.00	...
<i>k</i>	0	1	2	3	...	49	50	51	...
<i>alarm</i>	F	F	F	F	...	F	T	T	...
<i>xe</i>	0.00	1.50	3.50	5.20	...	77.35			...
<i>pxa</i>					...		77.35	77.35	...
<i>x</i>	0.00	1.50	3.50	5.20	...	77.35	77.35	77.35	...

EXAMPLE

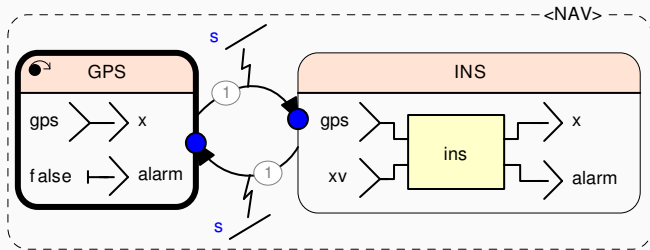

Can be compiled into simple constructs

EXAMPLE

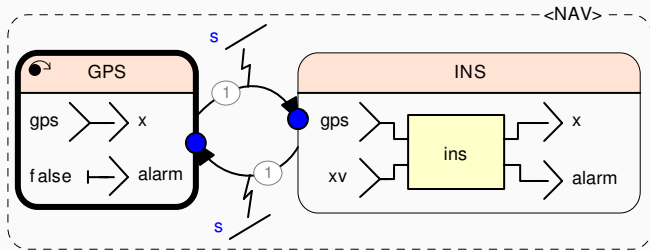

Can be compiled into simple constructs

We need a way to **reset the state of a node**

WITHOUT MODULAR RESET

```
node euler(x0, u: double, r: bool)
  returns (x: double);
let
  x = if r then x0 else x0 fby (x + 0.1 * u);
tel
```

```
node ins(gps, xv: double, r: bool)
  returns (x: double, alarm: bool)
  var k: int;
let
  x = merge alarm
      ((0. fby x) when alarm)
      (euler((gps, xv, r) whennot alarm));
  alarm = (k ≥ 50);
  k = if r then 0 else 0 fby (k + 1);
tel
...
(x, a) = ins(gps, xv, r);
```

WITHOUT MODULAR RESET

```

node euler(x0, u: double, r: bool)
  returns (x: double);
let
  x = if r then x0 else x0 fby (x + 0.1 * u);
tel

node ins(gps, xv: double, r: bool)
  returns (x: double, alarm: bool)
  var k: int;
let
  x = merge alarm
    ((0. fby x) when alarm)
    (euler((gps, xv, r) whenot alarm));
  alarm = (k ≥ 50);
  k = if r then 0 else 0 fby (k + 1);
tel
...
(x, a) = ins(gps, xv, r);

```

WITH MODULAR RESET

```

node euler(x0, u: double)
  returns (x: double);
let
  x = x0 fby (x + 0.1 * u);
tel

node ins(gps, xv: double)
  returns (x: double, alarm: bool)
  var pxa, xe: double; k: int;
let
  k = 0 fby (k + 1);
  alarm = (k ≥ 50);
  xe = euler((gps, xv) when not alarm);
  pxa = (0. fby x) when alarm;
  x = merge alarm pxa xe;
tel
...
(x, a) = (restart ins every r) (gps, xv);

```

GRAPHICAL MODULAR RESET CONSTRUCT

SCADE

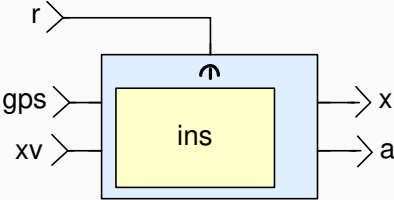

Simulink

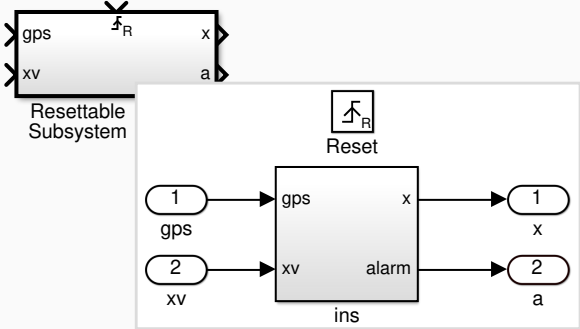

A SIMPLER EXAMPLE: INTUITIVE SEMANTICS

```
node nat(i: int)
  returns (n: int)
let
  n = i fby (n + 1);
tel
```

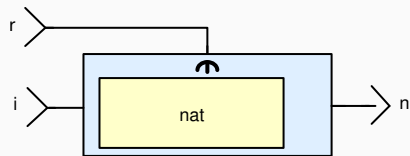
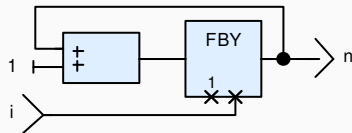

A SIMPLER EXAMPLE: INTUITIVE SEMANTICS

```
node nat(i: int)
  returns (n: int)
let
  n = i fby (n + 1);
tel
```

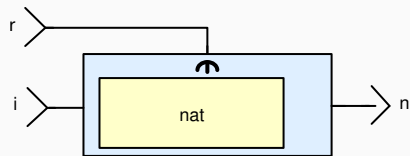
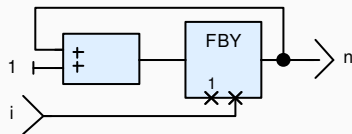

r	F
i	0
<hr/>	
$nat(i)$	0
$(\text{restart } nat \text{ every } r)(i)$	0

A SIMPLER EXAMPLE: INTUITIVE SEMANTICS

```
node nat(i: int)
  returns (n: int)
let
  n = i fby (n + 1);
tel
```

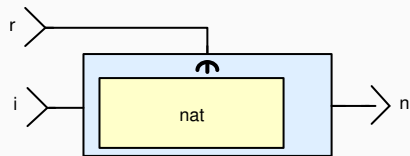
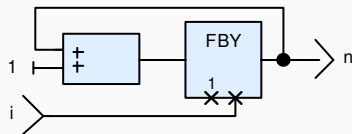

<i>r</i>	F	F
<i>i</i>	0	5
<hr/>		
<i>nat</i> (<i>i</i>)	0	1
(<code>restart nat every r</code>)(<i>i</i>)	0	1

A SIMPLER EXAMPLE: INTUITIVE SEMANTICS

```
node nat(i: int)
  returns (n: int)
let
  n = i fby (n + 1);
tel
```

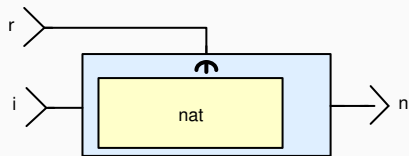
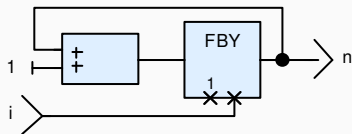

<i>r</i>	F	F	T
<i>i</i>	0	5	10
<hr/>			
<i>nat(i)</i>	0	1	2
<i>(restart nat every r)(i)</i>	0	1	10

A SIMPLER EXAMPLE: INTUITIVE SEMANTICS

```
node nat(i: int)
  returns (n: int)
let
  n = i fby (n + 1);
tel
```

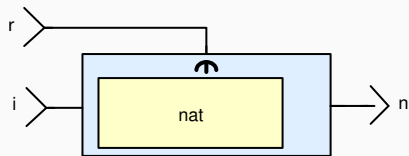
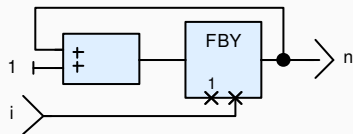

<i>r</i>	F	F	T	F
<i>i</i>	0	5	10	15
<hr/>				
<i>nat</i> (<i>i</i>)	0	1	2	3
(<i>restart nat every r</i>)(<i>i</i>)	0	1	10	11

A SIMPLER EXAMPLE: INTUITIVE SEMANTICS

```
node nat(i: int)
  returns (n: int)
let
  n = i fby (n + 1);
tel
```

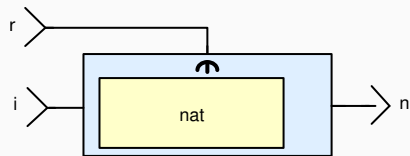
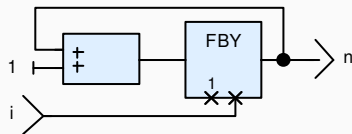

<i>r</i>	F	F	T	F	F
<i>i</i>	0	5	10	15	20
<hr/>					
<i>nat(i)</i>	0	1	2	3	4
<i>(restart nat every r)(i)</i>	0	1	10	11	12

A SIMPLER EXAMPLE: INTUITIVE SEMANTICS

```
node nat(i: int)
  returns (n: int)
let
  n = i fby (n + 1);
tel
```

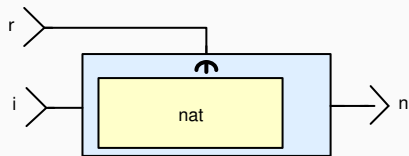
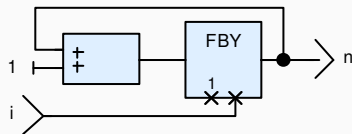

<i>r</i>	F	F	T	F	F	T
<i>i</i>	0	5	10	15	20	25
<hr/>						
<i>nat</i> (<i>i</i>)	0	1	2	3	4	5
(<i>restart nat every r</i>)(<i>i</i>)	0	1	10	11	12	25

A SIMPLER EXAMPLE: INTUITIVE SEMANTICS

```
node nat(i: int)
  returns (n: int)
let
  n = i fby (n + 1);
tel
```

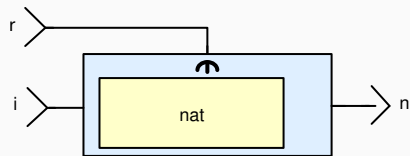
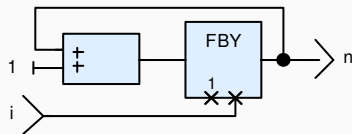

<i>r</i>	F	F	T	F	F	T	F
<i>i</i>	0	5	10	15	20	25	30
<hr/>							
<i>nat</i> (<i>i</i>)	0	1	2	3	4	5	6
(<i>restart nat every r</i>)(<i>i</i>)	0	1	10	11	12	25	26

A SIMPLER EXAMPLE: INTUITIVE SEMANTICS

```
node nat(i: int)
  returns (n: int)
let
  n = i fby (n + 1);
tel
```

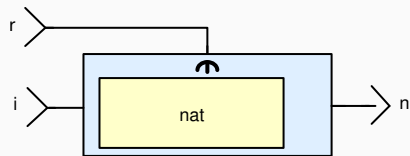
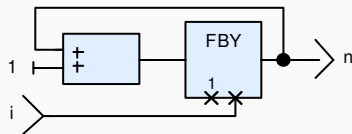

<i>r</i>	F	F	T	F	F	T	F	...
<i>i</i>	0	5	10	15	20	25	30	...
<hr/>								
<i>nat</i> (<i>i</i>)	0	1	2	3	4	5	6	...
(restart <i>nat</i> every <i>r</i>)(<i>i</i>)	0	1	10	11	12	25	26	...

A SIMPLER EXAMPLE: INTUITIVE SEMANTICS

```

node nat(i: int)
  returns (n: int)
let
  n = i fby (n + 1);
tel

```

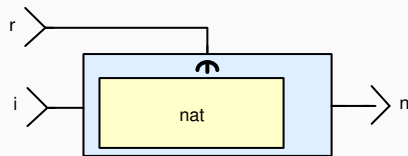
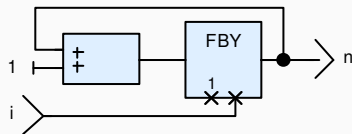

<i>r</i>	F	F	T	F	F	T	F	...
<i>i</i>	0	5	10	15	20	25	30	...
<hr/>								
<i>nat(i)</i>	0	1	2	3	4	5	6	...
(restart nat every r)(i)	0	1	10	11	12	25	26	...

Could be implemented in a higher-order recursive language

A SIMPLER EXAMPLE: INTUITIVE SEMANTICS

```

node nat(i: int)
  returns (n: int)
let
  n = i fby (n + 1);
tel

```

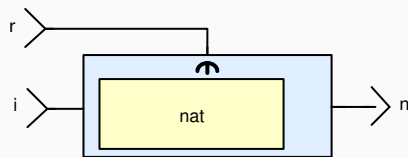
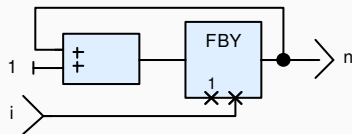

<i>r</i>	F	F	T	F	F	T	F	...
<i>i</i>	0	5	10	15	20	25	30	...
<i>nat</i> (<i>i</i>)	0	1	2	3	4	5	6	...
(restart nat every <i>r</i>)(<i>i</i>)	0	1	10	11	12	25	26	...

Could be implemented in a higher-order recursive language

A SIMPLER EXAMPLE: INTUITIVE SEMANTICS

```

node nat(i: int)
  returns (n: int)
let
  n = i fby (n + 1);
tel

```

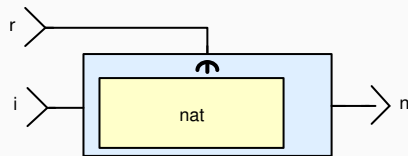
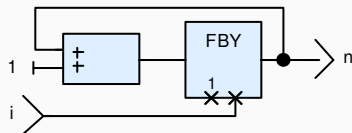

<i>r</i>	F	F	T	F	F	T	F	...
<i>i</i>	0	5	10	15	20	25	30	...
<i>nat</i> (<i>i</i>)	0	1	2	3	4	5	6	...
(restart nat every r)(<i>i</i>)	0	1	10	11	12	25	26	...

Could be implemented in a higher-order recursive language

A SIMPLER EXAMPLE: INTUITIVE SEMANTICS

r			F	F	T	F	F	T	F	...
<hr/>										
i			0	5	10	15	20	25	30	...

`(restart nat every r)(i)` 0 1 10 11 12 25 26 ...

A SIMPLER EXAMPLE: INTUITIVE SEMANTICS

r	F	F	T	F	F	T	F	...
<hr/>								
count r	0	0	1	1	1	2	2	...
i	0	5	10	15	20	25	30	...

(restart nat every r)(i) 0 1 10 11 12 25 26 ...

A SIMPLER EXAMPLE: INTUITIVE SEMANTICS

r	F	F	T	F	F	T	F	...
$\text{count } r$	0	0	1	1	1	2	2	...
i	0	5	10	15	20	25	30	...
$\text{mask}_r^0 i$	0	5						...

$(\text{restart nat every } r)(i)$ 0 1 10 11 12 25 26 ...

A SIMPLER EXAMPLE: INTUITIVE SEMANTICS

r	F	F	T	F	F	T	F	...
$\text{count } r$	0	0	1	1	1	2	2	...
i	0	5	10	15	20	25	30	...
$\text{mask}_r^0 i$	0	5						...
$\text{nat}(\text{mask}_r^0 i)$	0	1						...

$(\text{restart } \text{nat every } r)(i)$ 0 1 10 11 12 25 26 ...

A SIMPLER EXAMPLE: INTUITIVE SEMANTICS

r	F	F	T	F	F	T	F	...
$\text{count } r$	0	0	1	1	1	2	2	...
i	0	5	10	15	20	25	30	...
$\text{mask}_r^0 i$	0	5						...
$\text{nat}(\text{mask}_r^0 i)$	0	1						...
$\text{mask}_r^1 i$			10	15	20			...

$(\text{restart } \text{nat } \text{every } r)(i)$ 0 1 10 11 12 25 26 ...

A SIMPLER EXAMPLE: INTUITIVE SEMANTICS

r	F	F	T	F	F	T	F	...
$\text{count } r$	0	0	1	1	1	2	2	...
i	0	5	10	15	20	25	30	...
$\text{mask}_r^0 i$	0	5						...
$\text{nat}(\text{mask}_r^0 i)$	0	1						...
$\text{mask}_r^1 i$			10	15	20			...
$\text{nat}(\text{mask}_r^1 i)$			10	11	12			...
$(\text{restart } \text{nat } \text{every } r)(i)$	0	1	10	11	12	25	26	...

A SIMPLER EXAMPLE: INTUITIVE SEMANTICS

r	F	F	T	F	F	T	F	...
$\text{count } r$	0	0	1	1	1	2	2	...
i	0	5	10	15	20	25	30	...
$\text{mask}_r^0 i$	0	5						...
$\text{nat}(\text{mask}_r^0 i)$	0	1						...
$\text{mask}_r^1 i$			10	15	20			...
$\text{nat}(\text{mask}_r^1 i)$			10	11	12			...
$\text{mask}_r^2 i$						25	30	...
$(\text{restart } \text{nat } \text{every } r)(i)$	0	1	10	11	12	25	26	...

A SIMPLER EXAMPLE: INTUITIVE SEMANTICS

r	F	F	T	F	F	T	F	...
$\text{count } r$	0	0	1	1	1	2	2	...
i	0	5	10	15	20	25	30	...
$\text{mask}_r^0 i$	0	5						...
$\text{nat}(\text{mask}_r^0 i)$	0	1						...
$\text{mask}_r^1 i$			10	15	20			...
$\text{nat}(\text{mask}_r^1 i)$			10	11	12			...
$\text{mask}_r^2 i$						25	30	...
$\text{nat}(\text{mask}_r^2 i)$						25	26	...
$(\text{restart nat every } r)(i)$	0	1	10	11	12	25	26	...

A SIMPLER EXAMPLE: INTUITIVE SEMANTICS

r	F	F	T	F	F	T	F	...
$\text{count } r$	0	0	1	1	1	2	2	...
i	0	5	10	15	20	25	30	...
$\text{mask}_r^0 i$	0	5						...
$\text{nat}(\text{mask}_r^0 i)$	0	1						...
$\text{mask}_r^1 i$			10	15	20			...
$\text{nat}(\text{mask}_r^1 i)$			10	11	12			...
$\text{mask}_r^2 i$						25	30	...
$\text{nat}(\text{mask}_r^2 i)$						25	26	...
\vdots								
$(\text{restart nat every } r)(i)$	0	1	10	11	12	25	26	...

Node instantiation

$$H \vdash_{\text{eqn}} \mathbf{x} = f(\mathbf{e})$$

Node instantiation

$$\frac{H \vdash_{\text{exp}} e \Downarrow es}{H \vdash_{\text{eqn}} x = f(e)}$$

Node instantiation

$$\frac{H \vdash_{\text{exp}} e \Downarrow es \quad \vdash_{\text{node}} f(es) \Downarrow xs}{H \vdash_{\text{eqn}} x = f(e)}$$

Node instantiation

$$\frac{H \vdash_{\text{exp}} e \Downarrow es \quad \vdash_{\text{node}} f(es) \Downarrow xs \quad H(x) = xs}{H \vdash_{\text{eqn}} x = f(e)}$$

Node instantiation

$$\frac{H \vdash_{\text{exp}} e \Downarrow es \quad \vdash_{\text{node}} f(es) \Downarrow xs \quad H(x) = xs}{H \vdash_{\text{eqn}} x = f(e)}$$

Modular reset

$$H \vdash_{\text{eqn}} x = (\text{restart } f \text{ every } y)(e)$$

Node instantiation

$$\frac{H \vdash_{\text{exp}} e \Downarrow es \quad \vdash_{\text{node}} f(es) \Downarrow xs \quad H(x) = xs}{H \vdash_{\text{eqn}} x = f(e)}$$

Modular reset

$$\frac{H \vdash_{\text{exp}} e \Downarrow es \quad H(x) = xs}{H \vdash_{\text{eqn}} x = (\text{restart } f \text{ every } y)(e)}$$

Node instantiation

$$\frac{H \vdash_{\text{exp}} e \Downarrow es \quad \vdash_{\text{node}} f(es) \Downarrow xs \quad H(x) = xs}{H \vdash_{\text{eqn}} x = f(e)}$$

Modular reset

$$\frac{H(y) = rs \quad r = \text{bools-of } rs \quad H \vdash_{\text{exp}} e \Downarrow es \quad \forall k, \vdash_{\text{node}} f(\text{mask}_r^k es) \Downarrow \text{mask}_r^k xs \quad H(x) = xs}{H \vdash_{\text{eqn}} x = (\text{restart } f \text{ every } y)(e)}$$

Node instantiation

$$\frac{H \vdash_{\text{exp}} e \Downarrow es \quad \vdash_{\text{node}} f(es) \Downarrow xs \quad H(x) = xs}{H \vdash_{\text{eqn}} x = f(e)}$$

Modular reset

$$\frac{H(y) = rs \quad r = \text{bools-of } rs \quad H \vdash_{\text{exp}} e \Downarrow es \quad \forall k, \vdash_{\text{node}} f(\text{mask}_r^k es) \Downarrow \text{mask}_r^k xs \quad H(x) = xs}{H \vdash_{\text{eqn}} x = (\text{restart } f \text{ every } y)(e)}$$

Universally quantified relation: unbounded number of constraints

VÉLUS: A VERIFIED LUSTRE COMPILER

Implemented in Coq and (some) OCaml

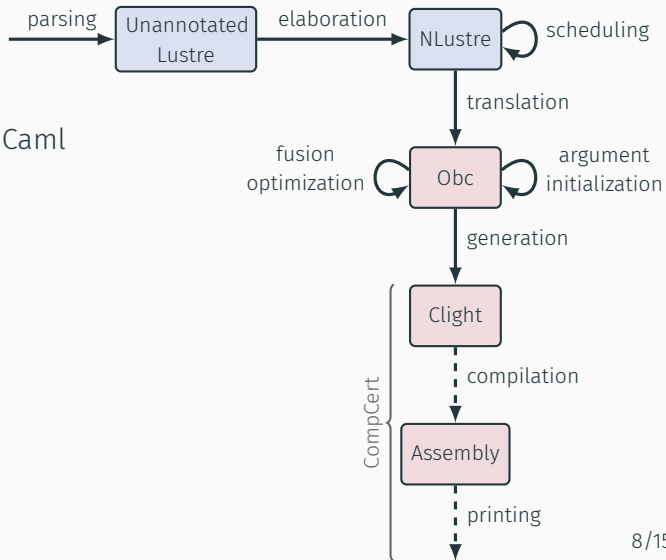

- validated **parsing** (`menhir --coq`)

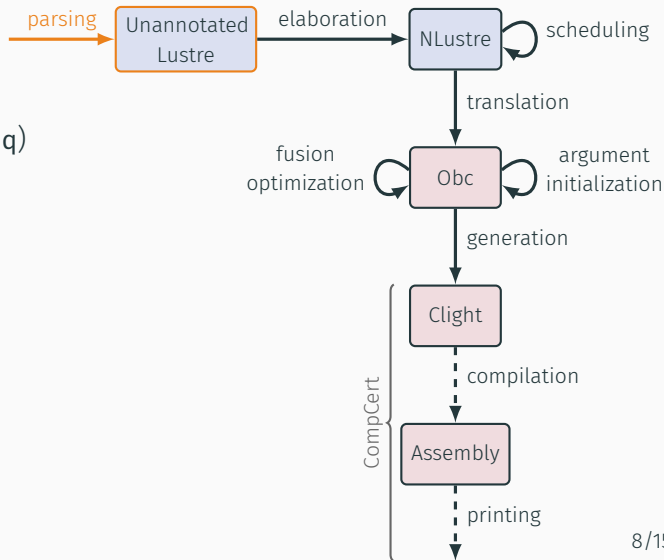

VÉLUS: A VERIFIED LUSTRE COMPILER

- validated parsing (`menhir --coq`)
- **elaboration** to get clock and type information

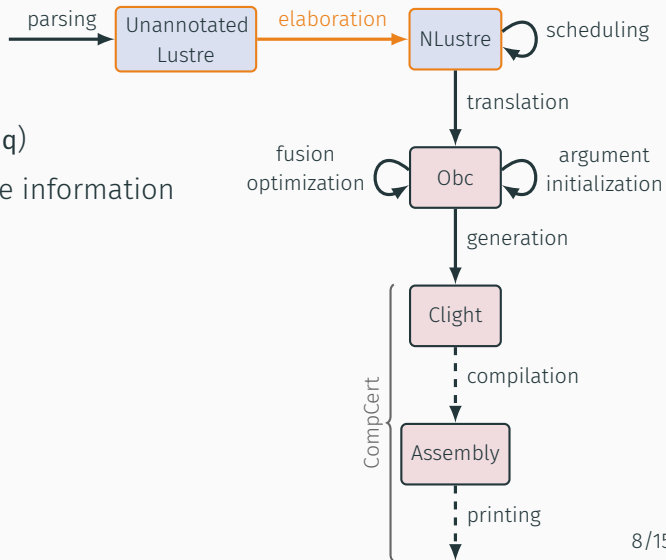

VÉLUS: A VERIFIED LUSTRE COMPILER

- validated parsing (`menhir --coq`)
- elaboration to get clock and type information
- **scheduling** of NLustre code

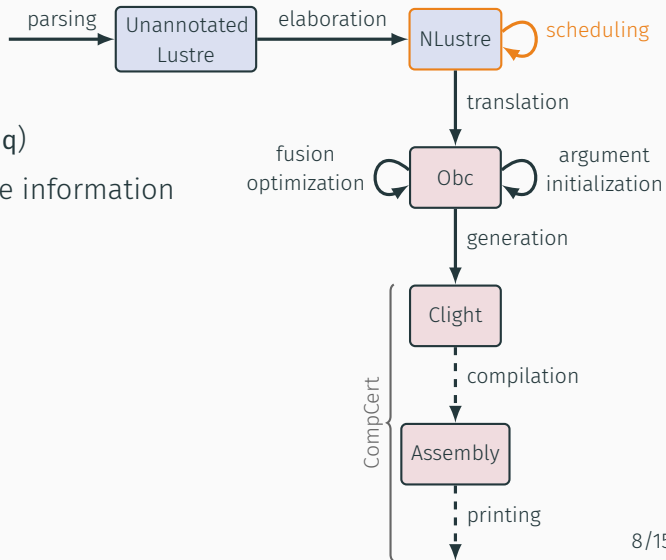

VÉLUS: A VERIFIED LUSTRE COMPILER

- validated parsing (`menhir --coq`)
- elaboration to get clock and type information
- scheduling of NLustre code
- **translation** to Obc code

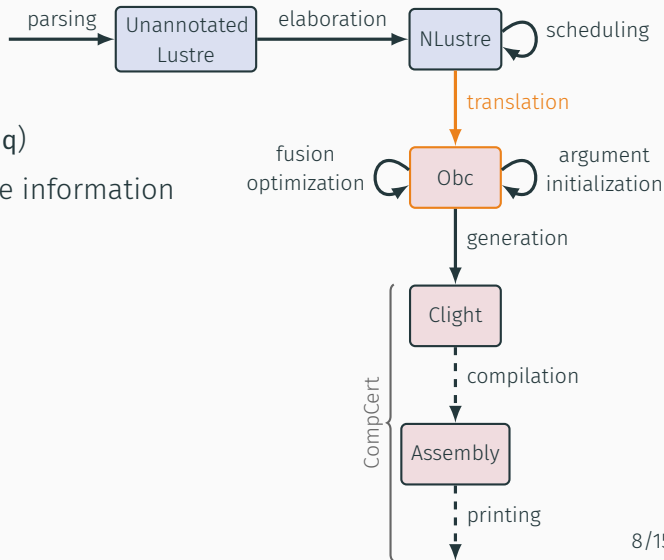

VÉLUS: A VERIFIED LUSTRE COMPILER

- validated parsing (`menhir --coq`)
- elaboration to get clock and type information
- scheduling of NLustre code
- translation to Obc code
- fusion optimization of conditionals

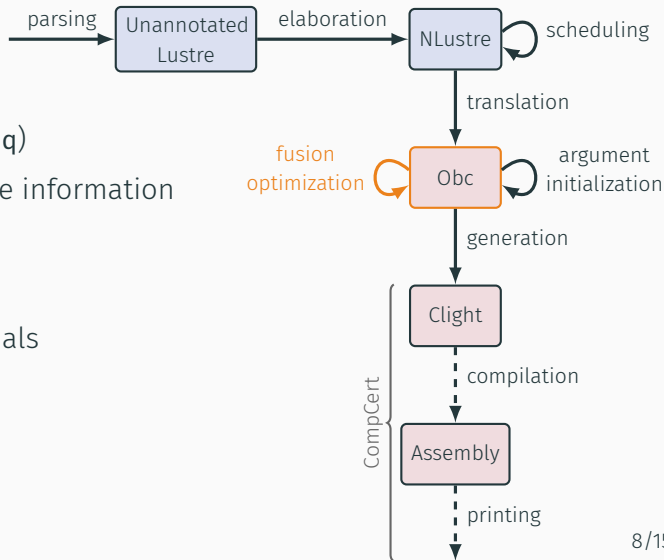

VÉLUS: A VERIFIED LUSTRE COMPILER

- validated parsing (`menhir --coq`)
- elaboration to get clock and type information
- scheduling of NLustre code
- translation to Obc code
- fusion optimization of conditionals
- **initialization** of variable arguments

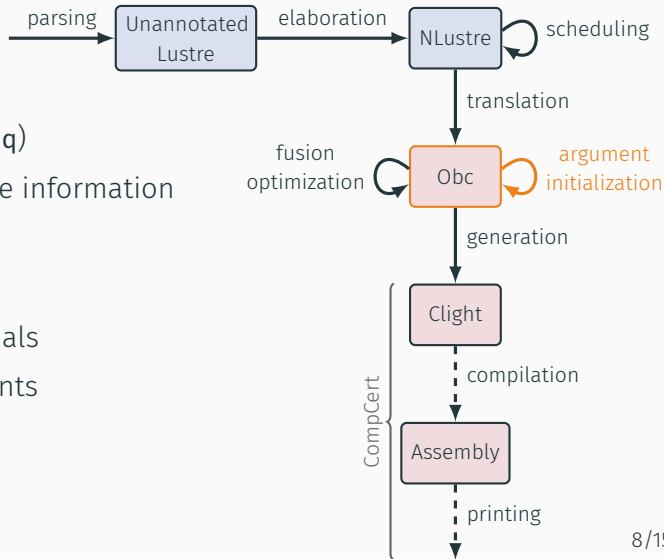

VÉLUS: A VERIFIED LUSTRE COMPILER

- validated parsing (`menhir --coq`)
- elaboration to get clock and type information
- scheduling of NLustre code
- translation to Obc code
- fusion optimization of conditionals
- initialization of variable arguments
- **Generation** of Clight code

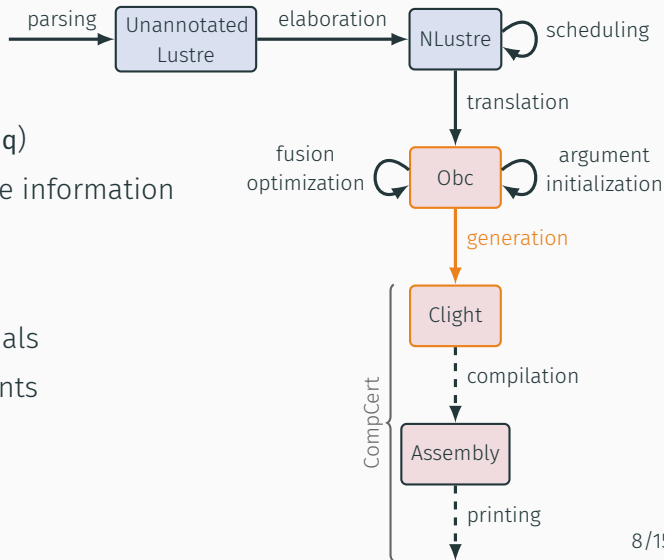

VÉLUS: A VERIFIED LUSTRE COMPILER

- validated parsing (`menhir --coq`)
- elaboration to get clock and type information
- scheduling of NLustre code
- translation to Obc code
- fusion optimization of conditionals
- initialization of variable arguments
- Generation of Clight code
- Rely on CompCert for **compilation**

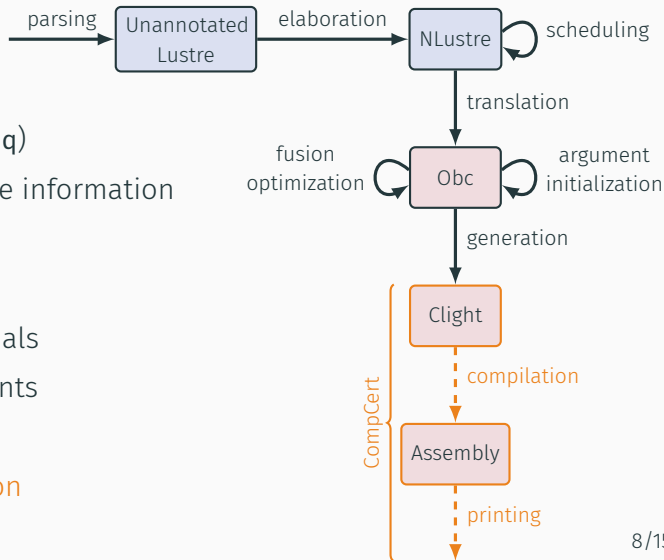

A PROBLEM WITH THE COMPILATION FROM NLUSTRE TO OBC

```
node driver(x0, y0, u, v: double, r: bool)
  returns (x, y: double)
  var ax, ay: bool;
let
  x, ax = (restart ins every r)(x0, u);
  y, ay = (restart ins every r)(y0, v);
tel
```

```
class driver {
  instance x: ins, y: ins;

  reset() { ins(x).reset();
           ins(y).reset() }

  step(x0, y0, u, v: double, r: bool)
  returns (x, y: double)
  var ax, ay: bool
  {
    if r { ins(x).reset() };
    x, ax := ins(x).step(x0, u);
    if r { ins(y).reset() };
    y, ay := ins(y).step(y0, v)
  }
}
```

A PROBLEM WITH THE COMPILATION FROM NLUSTRE TO OBC

```
node driver(x0, y0, u, v: double, r: bool)
  returns (x, y: double)
  var ax, ay: bool;
let
  x, ax = (restart ins every r)(x0, u);
  y, ay = (restart ins every r)(y0, v);
tel
```

```
class driver {
  instance x: ins, y: ins;

  reset() { ins(x).reset();
           ins(y).reset() }

  step(x0, y0, u, v: double, r: bool)
  returns (x, y: double)
  var ax, ay: bool
  {
    if r { ins(x).reset() };
    x, ax := ins(x).step(x0, u);
    if r { ins(y).reset() };
    y, ay := ins(y).step(y0, v)
  }
}
```

A PROBLEM WITH THE COMPILATION FROM NLUSTRE TO OBC

```
node driver(x0, y0, u, v: double, r: bool)
  returns (x, y: double)
  var ax, ay: bool;
let
  x, ax = (restart ins every r)(x0, u);
  y, ay = (restart ins every r)(y0, v);
tel
```

```
class driver {
  instance x: ins, y: ins;

  reset() { ins(x).reset();
           ins(y).reset() }

  step(x0, y0, u, v: double, r: bool)
  returns (x, y: double)
  var ax, ay: bool
  {
    if r { ins(x).reset() };
    x, ax := ins(x).step(x0, u);
    if r { ins(y).reset() };
    y, ay := ins(y).step(y0, v)
  }
}
```

A PROBLEM WITH THE COMPILATION FROM NLUSTRE TO OBC

```
node driver(x0, y0, u, v: double, r: bool)
  returns (x, y: double)
  var ax, ay: bool;
let
  x, ax = (restart ins every r)(x0, u);
  y, ay = (restart ins every r)(y0, v);
tel
```

```
class driver {
  instance x: ins, y: ins;

  reset() { ins(x).reset();
           ins(y).reset() }

  step(x0, y0, u, v: double, r: bool)
  returns (x, y: double)
  var ax, ay: bool
  {
    if r { ins(x).reset() };
    x, ax := ins(x).step(x0, u);
    if r { ins(y).reset() };
    y, ay := ins(y).step(y0, v)
  }
}
```

Propose a new intermediate language

- **Invariant semantics** under permutation
- **Separate reset** construct
- **Explicit state**: state variables and instances

STC: SYNCHRONOUS TRANSITION CODE

Propose a new intermediate language

- **Invariant semantics** under permutation
- **Separate reset** construct
- **Explicit state**: state variables and instances

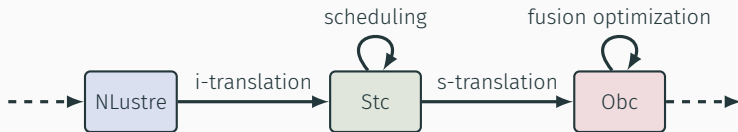

COMPILATION WITH STC

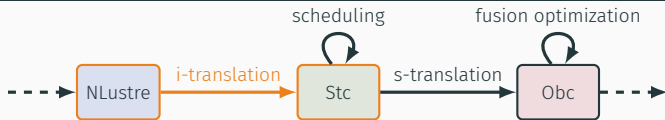

```
node driver(x0, y0, u, v: double, r: bool)
  returns (x, y: double)
  var ax, ay: bool;
let
  x, ax = (restart ins every r)(x0, u);
  y, ay = (restart ins every r)(y0, v);
tel
```

```
system driver {
  sub x: ins, y: ins;

  transition(x0, y0, u, v: double, r: bool)
    returns (x, y: double)
    var ax, ay: bool;
  {
    x, ax = ins<x>(x0, u);
    reset ins<x> every (. on r);
    y, ay = ins<y>(y0, v);
    reset ins<y> every (. on r);
  }
}
```

COMPILATION WITH STC

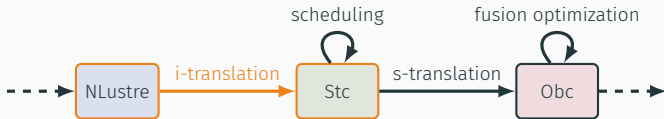

```
node driver(x0, y0, u, v: double, r: bool)
  returns (x, y: double)
  var ax, ay: bool;
let
  x, ax = (restart ins every r)(x0, u);
  y, ay = (restart ins every r)(y0, v);
tel
```

```
system driver {
  sub x: ins, y: ins;

  transition(x0, y0, u, v: double, r: bool)
    returns (x, y: double)
    var ax, ay: bool;
    {
      x, ax = ins<x>(x0, u);
      reset ins<x> every (. on r);
      y, ay = ins<y>(y0, v);
      reset ins<y> every (. on r);
    }
}
```

COMPILATION WITH STC

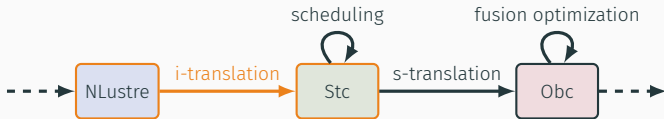

```
node driver(x0, y0, u, v: double, r: bool)
  returns (x, y: double)
  var ax, ay: bool;
let
  x, ax = (restart ins every r)(x0, u);
  y, ay = (restart ins every r)(y0, v);
tel
```

```
system driver {
  sub x: ins, y: ins;

  transition(x0, y0, u, v: double, r: bool)
    returns (x, y: double)
    var ax, ay: bool;
  {
    x, ax = ins<x>(x0, u);
    reset ins<x> every (. on r);
    y, ay = ins<y>(y0, v);
    reset ins<y> every (. on r);
  }
}
```

COMPILATION WITH STC

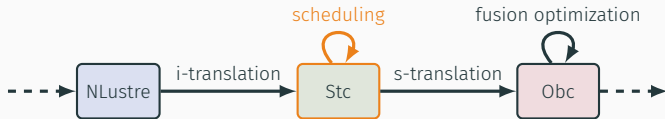

```
node driver(x0, y0, u, v: double, r: bool)
  returns (x, y: double)
  var ax, ay: bool;
let
  x, ax = (restart ins every r)(x0, u);
  y, ay = (restart ins every r)(y0, v);
tel
```

```
system driver {
  sub x: ins, y: ins;

  transition(x0, y0, u, v: double, r: bool)
    returns (x, y: double)
    var ax, ay: bool;
    {
      reset ins<x> every (. on r);
      reset ins<y> every (. on r);
      x, ax = ins<x>(x0, u);
      y, ay = ins<y>(y0, v);
    }
}
```

COMPILATION WITH STC

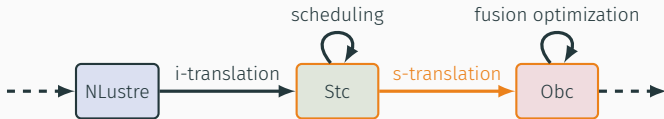

```
system driver {  
  sub x: ins, y: ins;
```

```
  transition(x0, y0, u, v: double, r: bool)  
    returns (x, y: double)  
    var ax, ay: bool;  
  {  
    reset ins<x> every (. on r);  
    reset ins<y> every (. on r);  
    x, ax = ins<x>(x0, u);  
    y, ay = ins<y>(y0, v);  
  }  
}
```

```
class driver {
```

```
  instance x: ins, y: ins;
```

```
  reset() { ins(x).reset();  
           ins(y).reset() }
```

```
  step(x0, y0, u, v: double, r: bool)  
    returns (x, y: double)  
    var ax, ay: bool  
  {  
    if r { ins(x).reset() };  
    if r { ins(y).reset() };  
    x, ax := ins(x).step(x0, u);  
    y, ay := ins(y).step(y0, v)  
  }  
}
```

COMPILATION WITH STC

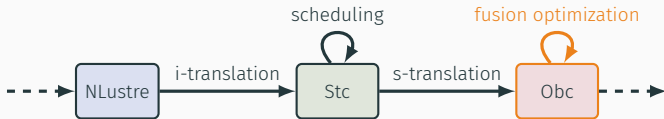

```
system driver {  
  sub x: ins, y: ins;
```

```
  transition(x0, y0, u, v: double, r: bool)  
    returns (x, y: double)  
    var ax, ay: bool;  
  {  
    reset ins<x> every (. on r);  
    reset ins<y> every (. on r);  
    x, ax = ins<x>(x0, u);  
    y, ay = ins<y>(y0, v);  
  }  
}
```

```
class driver {  
  instance x: ins, y: ins;
```

```
  reset() { ins(x).reset();  
           ins(y).reset() }  
  
  step(x0, y0, u, v: double, r: bool)  
    returns (x, y: double)  
    var ax, ay: bool  
  {  
    if r { ins(x).reset();  
          ins(y).reset() };  
    x, ax := ins(x).step(x0, u);  
    y, ay := ins(y).step(y0, v)  
  }  
}
```

Transition system

- Start state S , end state S'
- Transition constraints
- Transient state l

Transition system

- Start state S , end state S'
- Transition constraints
- Transient state l

```
system driver {  
  sub x: ins, y: ins;  
  
  transition(x0, y0, u, v: double, r: bool)  
    returns (x, y: double)  
    var ax, ay: bool;  
  {  
    x, ax = ins<x>(x0, u);  
    reset ins<x> every (. on r);  
    y, ay = ins<y>(y0, v);  
    reset ins<y> every (. on r);  
  }  
}
```

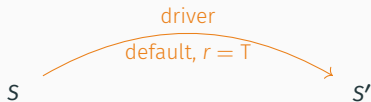

Transition system

- Start state S , end state S'
- Transition constraints
- Transient state I

```
system driver {  
  sub x: ins, y: ins;  
  
  transition(x0, y0, u, v: double, r: bool)  
    returns (x, y: double)  
    var ax, ay: bool;  
  {  
    x, ax = ins<x>(x0, u);  
    reset ins<x> every (. on r);  
    y, ay = ins<y>(y0, v);  
    reset ins<y> every (. on r);  
  }  
}
```

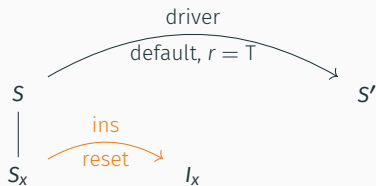

Transition system

- Start state S , end state S'
- Transition constraints
- Transient state I

```
system driver {  
  sub x: ins, y: ins;  
  
  transition(x0, y0, u, v: double, r: bool)  
    returns (x, y: double)  
    var ax, ay: bool;  
  {  
    x, ax = ins<x>(x0, u);  
    reset ins<x> every (. on r);  
    y, ay = ins<y>(y0, v);  
    reset ins<y> every (. on r);  
  }  
}
```

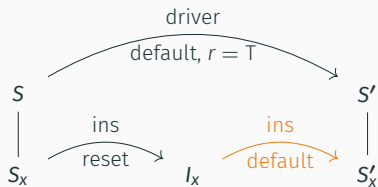

Transition system

- Start state S , end state S'
- Transition constraints
- Transient state I

```

system driver {
  sub x: ins, y: ins;

  transition(x0, y0, u, v: double, r: bool)
    returns (x, y: double)
    var ax, ay: bool;
  {
    x, ax = ins<x>(x0, u);
    reset ins<x> every (. on r);
    y, ay = ins<y>(y0, v);
    reset ins<y> every (. on r);
  }
}
    
```

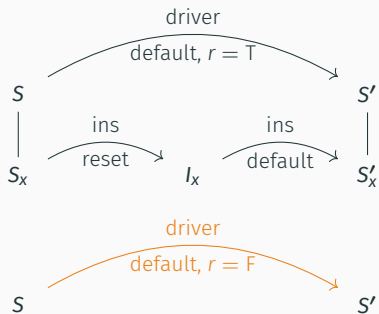

STC INTUITIVE SEMANTICS

Transition system

- Start state S , end state S'
- Transition constraints
- Transient state I

```
system driver {  
  sub x: ins, y: ins;  
  
  transition(x0, y0, u, v: double, r: bool)  
    returns (x, y: double)  
    var ax, ay: bool;  
  {  
    x, ax = ins<x>(x0, u);  
    reset ins<x> every (. on r);  
    y, ay = ins<y>(y0, v);  
    reset ins<y> every (. on r);  
  }  
}
```

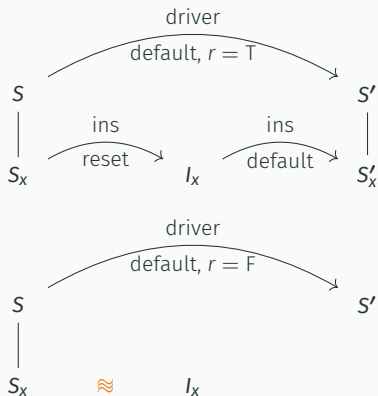

STC INTUITIVE SEMANTICS

Transition system

- Start state S , end state S'
- Transition constraints
- Transient state I

```
system driver {  
  sub x: ins, y: ins;  
  
  transition(x0, y0, u, v: double, r: bool)  
  returns (x, y: double)  
  var ax, ay: bool;  
  {  
    x, ax = ins<x>(x0, u);  
    reset ins<x> every (. on r);  
    y, ay = ins<y>(y0, v);  
    reset ins<y> every (. on r);  
  }  
}
```

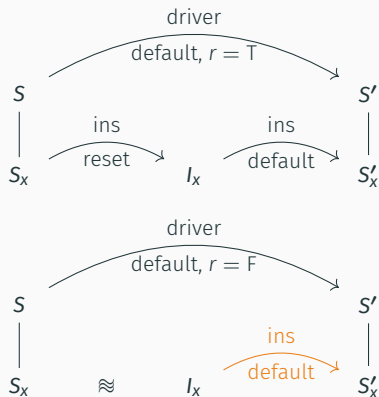

CORRECTNESS: PRESERVATION OF THE SEMANTICS

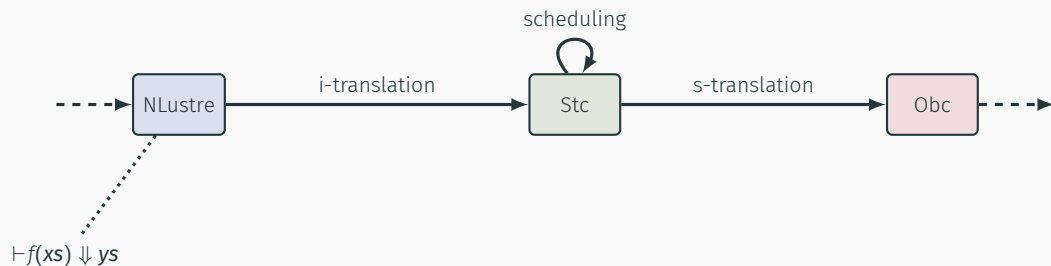

CORRECTNESS: PRESERVATION OF THE SEMANTICS

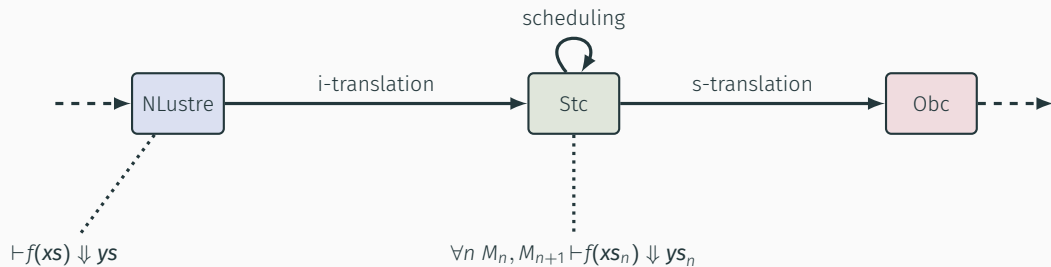

CORRECTNESS: PRESERVATION OF THE SEMANTICS

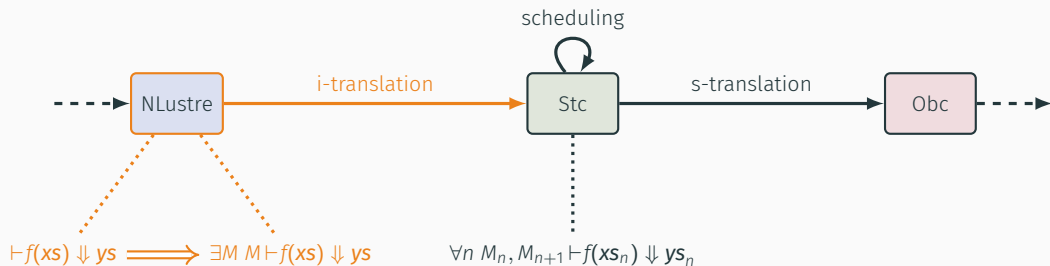

CORRECTNESS: PRESERVATION OF THE SEMANTICS

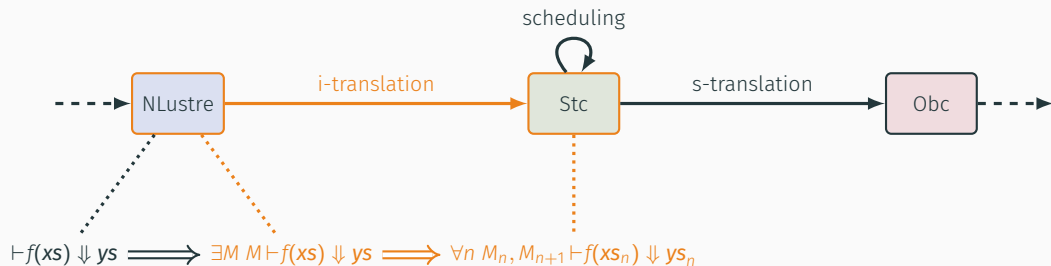

CORRECTNESS: PRESERVATION OF THE SEMANTICS

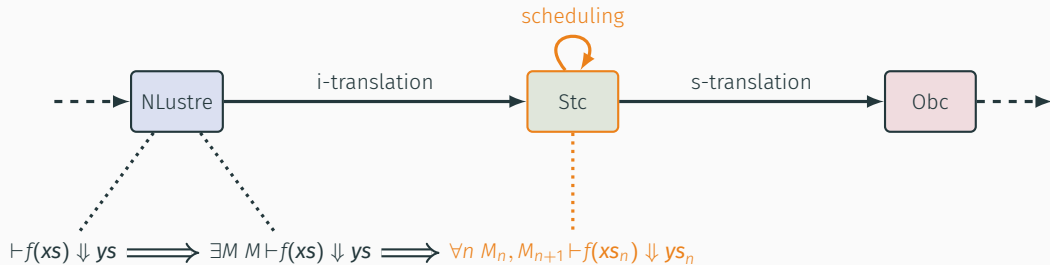

CORRECTNESS: PRESERVATION OF THE SEMANTICS

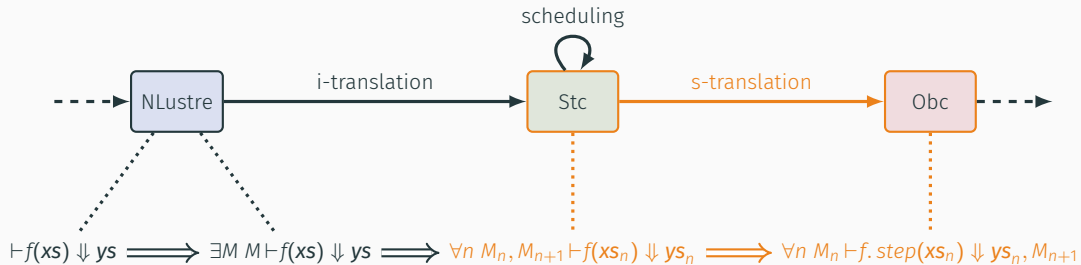

Theorem (Vélus correctness)

Given a list of declarations D , a name f , lists of streams of values \mathbf{xs} and \mathbf{ys} , an NLustre program G and an assembly program P such that $\text{compile } D \ f = \text{OK } (G, P)$ and $G \vdash f(\mathbf{xs}) \Downarrow \mathbf{ys}$, then there exists an infinite trace of events T such that

$$P \Downarrow_{ASM} \text{Reacts}(T) \quad \text{and} \quad \text{bisim-IO}^G f \ \mathbf{xs} \ \mathbf{ys} \ T$$

Theorem (Vélus correctness)

Given a list of declarations D , a name f , lists of streams of values \mathbf{xs} and \mathbf{ys} , an NLustre program G and an assembly program P such that $\text{compile } D \ f = \text{OK } (G, P)$ and $G \vdash f(\mathbf{xs}) \Downarrow \mathbf{ys}$, then there exists an infinite trace of events T such that

$$P \Downarrow_{ASM} \text{Reacts}(T) \quad \text{and} \quad \text{bisim-IO}^G f \ \mathbf{xs} \ \mathbf{ys} \ T$$

Theorem (Vélus correctness)

Given a list of declarations D , a name f , lists of streams of values \mathbf{xs} and \mathbf{ys} , an NLustre program G and an assembly program P such that $\text{compile } D \ f = \text{OK } (G, P)$ and $G \vdash f(\mathbf{xs}) \Downarrow \mathbf{ys}$, then there exists an infinite trace of events T such that

$$P \Downarrow_{ASM} \text{Reacts}(T) \quad \text{and} \quad \text{bisim-IO}^G f \ \mathbf{xs} \ \mathbf{ys} \ T$$

Theorem (Vélus correctness)

Given a list of declarations D , a name f , lists of streams of values \mathbf{xs} and \mathbf{ys} , an NLustre program G and an assembly program P such that $\text{compile } D \ f = \text{OK } (G, P)$ and $G \vdash f(\mathbf{xs}) \Downarrow \mathbf{ys}$, then there exists an infinite trace of events T such that

$$P \Downarrow_{ASM} \text{Reacts}(T) \quad \text{and} \quad \text{bisim-IO}^G f \ \mathbf{xs} \ \mathbf{ys} \ T$$

Theorem (Vélus correctness)

Given a list of declarations D , a name f , lists of streams of values \mathbf{xs} and \mathbf{ys} , an NLustre program G and an assembly program P such that $\text{compile } D \ f = \text{OK } (G, P)$ and $G \vdash f(\mathbf{xs}) \Downarrow \mathbf{ys}$, then there exists an infinite trace of events T such that

$$P \Downarrow_{ASM} \text{Reacts}(T) \quad \text{and} \quad \text{bisim-IO}^G \ f \ \mathbf{xs} \ \mathbf{ys} \ T$$

ULTIMATE THEOREM

Theorem (Vélus correctness)

Given a list of declarations D , a name f , lists of streams of values xs and ys , an NLustre program G and an assembly program P such that $\text{compile } D \ f = \text{OK } (G, P)$ and $G \vdash f(xs) \Downarrow ys$, then there exists an infinite trace of events T such that

$$P \Downarrow_{ASM} \text{Reacts}(T) \quad \text{and} \quad \text{bisim-IO}^G \ f \ xs \ ys \ T$$

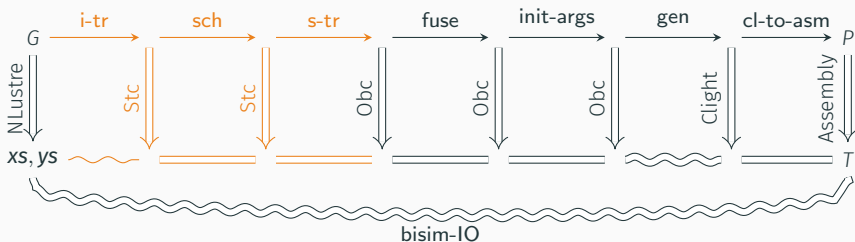

Contributions:

- A verified compiler for Lustre with reset
- A single additional semantic rule for the reset
- An intermediate transition system language: Stc

Next goal: State machines

`velus.inria.fr`
`github.com/INRIA/velus`

REFERENCES I

- Paul Caspi, Daniel Pilaud, Nicolas Halbwachs, and John Alexander Plaice (1987). “LUSTRE: A Declarative Language for Programming Synchronous Systems”. In: *In 14th Symposium on Principles of Programming Languages (POPL'87)*. ACM.
- Paul Caspi (Jan. 1, 1994). “Towards Recursive Block Diagrams”. In: *Annual Review in Automatic Programming* 18, pp. 81–85.
- Grégoire Hamon and Marc Pouzet (2000). “Modular Resetting of Synchronous Data-Flow Programs”. In: *Proceedings of the 2Nd ACM SIGPLAN International Conference on Principles and Practice of Declarative Programming*. PPDP '00. New York, NY, USA: ACM, pp. 289–300.
- Jean-Louis Colaço, Bruno Pagano, and Marc Pouzet (2005). “A Conservative Extension of Synchronous Data-Flow with State Machines”. In: *Proceedings of the 5th ACM International Conference on Embedded Software*. EMSOFT '05. New York, NY, USA: ACM, pp. 173–182.
- Sandrine Blazy and Xavier Leroy (Oct. 1, 2009). “Mechanized Semantics for the Clight Subset of the C Language”. In: *Journal of Automated Reasoning* 43.3, pp. 263–288.

REFERENCES II

- Xavier Leroy (July 2009). “Formal Verification of a Realistic Compiler”. In: *Communications of the ACM* 52.7, pp. 107–115.
- Jacques-Henri Jourdan, François Pottier, and Xavier Leroy (2012). “Validating LR(1) Parsers”. In: *Programming Languages and Systems*. Ed. by Helmut Seidl. Lecture Notes in Computer Science. Springer Berlin Heidelberg, pp. 397–416.
- Timothy Bourke, Lélío Brun, Pierre-Évariste Dagand, Xavier Leroy, Marc Pouzet, and Lionel Rieg (2017). “A Formally Verified Compiler for Lustre”. In: *Proceedings of the 38th ACM SIGPLAN Conference on Programming Language Design and Implementation*. PLDI 2017. New York, NY, USA: ACM, pp. 586–601.
- Jean-Louis Colaço, Bruno Pagano, and Marc Pouzet (Sept. 2017). “SCADE 6: A Formal Language for Embedded Critical Software Development”. In: *2017 International Symposium on Theoretical Aspects of Software Engineering (TASE)*, pp. 1–11.